

THE DALEK

**BUILD
THE ICONIC
BBC**



MONSTER



**COMEDY
DALEKS!**



**STEP-BY-STEP
INSTRUCTIONS**

Published
weekly • £11.99
AUS • \$23.99



DALEK

ISSUE 77



ADVENTURES IN TIME AND SPACE: THE CURSE OF DAVROS

3

The Doctor and Davros swap bodies on the eve of the Battle of Waterloo.



BEHIND THE SCENES: THE CURSE OF FATAL DEATH

6

The Daleks appeared in the 1999 *Doctor Who* Comic Relief spoof.

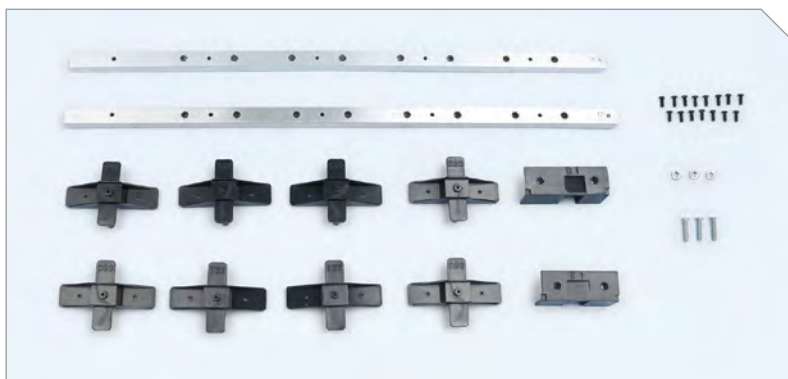

STEP-BY-STEP BUILD: PART 77

8

Side supports, skirt fixings, joints and all the required nuts and bolts.

Reader Services

CUSTOMER SERVICE IN THE UK
AND REPUBLIC OF IRELAND

How to continue your collection:

Subscribe online at hachettepartworks.com/Dalek or contact the Customer Service team via hachettepartworks.com/contact

Customer service & back orders:

Please visit hachettepartworks.com/contact to get in touch.

UK call 0345 155 9277

ROI call (01) 9079762

(Calls are charged at your local rate from a landline)

Published by Hachette Partworks Ltd
4th Floor, Jordan House, 47 Brunswick Place, London N1 6EB

General Manager – Isabelle Couderc
Editorial Director – Helen Nally
Marketing Director – Elise Windmill
Production Director – Sema Sant Anna
Managing Editor – Sarah Gale
Distribution Manager – Paul Smith
Product Manager – Rhys Myner

Packaged by Panini Publishing, a division of Panini UK Limited.

Publishing Director Europe – Marco M. Lupoi
Managing Director – Chris Clover
Managing Editor – Alan O'Keefe
Senior Editor – Karen O'Brien
Editor – John Ainsworth
Designer – Barry Spiers
Features Writer – Stuart Ashley

Distributed in the UK and Republic of Ireland by Marketforce.

© 2026 Hachette Partworks Ltd

Printed in the UK.

ISSN 2977-5574

ALL RIGHTS RESERVED

The editor's policy is to use papers that are natural, renewable and recyclable products and made from wood grown in sustainable forests. The logging and manufacturing processes are expected to conform to the environmental regulations of the country of origin.

In the event of a significant increase in production and transport costs, the publisher reserves the right to modify its selling prices.

BBC, DOCTOR WHO, TARDIS and DALEK (word marks and devices) are trade marks of the British Broadcasting Corporation and are used under licence. BBC logo © BBC 1996. DOCTOR WHO logo © BBC 1973. Dalek image © BBC/Terry Nation 1963. Licensed by BBC Studios.

The device complies with Part 15 of the FCC Rules. Operation is subject to the following two conditions: (1) this device may not cause harmful interference, and (2) this device must accept any interference received, including interference that may cause undesired operation.

All parts belong to a kit. NOT SUITABLE FOR CHILDREN UNDER THE AGE OF 14. This product is not a toy and is not intended for use in play. Follow the instructions in the enclosed magazines carefully and keep the appropriate information in a safe place. The installation of the electrical and electronic parts must always be carried out by an adult. Requires batteries.

BBC



For our environmental policy in full please scan the QR code here.

hachette
PARTWORKS LTD

THE CURSE OF DAVROS

The Doctor is trapped on a doomed Dalek ship careering through the time vortex.

Big Finish Productions
Audio Drama
Released: January 2012

Dartford, 2012. Philippa 'Flip' Jackson and Jared Ramon are taking a night bus back to their homes when they see a flying saucer on fire, careening across the sky. It crashes nearby. Flip jumps off the bus to investigate, and Jared follows her. Flip is concerned about any survivors, while Jared thinks he might be able to make money selling his story to the papers.

They walk across a common and discover that army trucks are surrounding the crash site. They find the saucer's escape capsule on the common. Flip and Jared are shocked to find the Doctor – whom they met a year earlier – inside. The Doctor doesn't remember them. Flip helps him out of the capsule, and they take him back to her flat.

Morning arrives. The Doctor lies on a bed in Flip's spare room, only half conscious. "You cannot do this to me..." he says, with the sinister voice of Davros echoing in his mind. He still appears to have no memory of Flip. He explains that he is being hunted by the Daleks.

Jared goes to the police and speaks to Superintendent Finch. Jared tells him about the escape capsule and the Doctor. He gives Finch Flip's address, not realising that Finch is a Dalek puppet.



Flip answers the front door. Jared is standing there, but his manner is strangely formal, and he doesn't recognise Flip. Jared finds the Doctor in the kitchen and starts chanting, "Exterminate!" He pulls out a Dalek gunstick and attacks. The Doctor and Flip race out of the flat and jump on a bus. The Doctor tells Flip that a Dalek mind has invaded Jared's body. Jared's mind is now probably trapped inside a Dalek on their pursuit ship.

The Doctor modifies Flip's phone to listen in on the Daleks' telepathic communications. He locates the Dalek ship and leaves the phone on the bus. The ship is in a car park, rendered invisible by a prismatic forcefield. They encounter Daleks inside the supermarket where Flip works.

Elsewhere, the Supreme Dalek confers with the Dalek Emperor, Davros. He insists that the Doctor be brought to him: "It is time we renewed our acquaintance."

Jared is returned to his own body, and they are all taken to the Dalek ship. The Doctor breaks out of their cell, and the trio escape the ship when it lands. They find themselves in the Belgian countryside in 1815. They are taken captive by French soldiers. The Doctor tells his two companions that the Daleks are determined to change the course of human history.

Flip is taken to the leader of the French army, Napoléon Bonaparte. He is aware that Flip comes from the future – he has been working with the Daleks. He wants to know how history will remember him. Flip says that he will surrender at Waterloo, but Bonaparte insists that will never happen.

The Doctor and Jared are reunited with Flip. The Doctor shoots a corporal and they make their escape through a wood.

Bonaparte contacts the Daleks and tells them of the Doctor's escape. He insists he has no men to spare to search for him, so Daleks are dispatched instead.

Jared is separated from the Doctor and Flip. He is caught by a Belgian soldier.

Bonaparte speaks with his generals. He learns that the Prussian army has been cut off from Waterloo and assures them that Lord Wellington's forces will fall.

The Doctor and Flip reach a large chateau, which is actually a shell for a Dalek mothership. They enter the command centre and find Davros. "So, we are reunited at last," he says. He points out that he can summon Daleks in an instant. "If you so much as lift a finger, your friend will die," the Doctor replies. Flip is confused by the Doctor's comment. The Doctor points his gun at Davros. Flip

is shocked by his ruthlessness and blocks his aim. She has realised the truth – he is not the Doctor at all. "I am Davros," he states. Flip turns to look at the elderly man in the chair. "My dear... I am the Doctor," he says.

Davros explains that the Doctor used the Daleks' mind-exchange technology to impersonate him. The Doctor refuses to reveal his plan. "That's the sort of thing you'd do," he says, chuckling. Davros intends to kill the Doctor and keep his body. Daleks arrive. The Doctor orders them to exterminate the 'Doctor' if he harms him or Flip. Davros tries to convince the Daleks of the truth but fails. He is taken to a cell.

Davros tells his Dalek guard details of the first time the mind-exchange technology was used on an invaded planet. He asks it to check his statements with the Supreme Dalek.

Jared mentions the Daleks to the Belgian soldier. He is taken to the Duke of Wellington, who knows that the Daleks are Bonaparte's new allies. Jared tells him that they are aliens with weapons more powerful than cannons. The Battle of Waterloo begins. Jared escapes.

The Supreme Dalek scans Davros' brain, and his identity is verified. They listen to the Doctor speaking to Flip.

The Doctor explains that he infiltrated the Dalek mothership and overheard Davros and the Supreme Dalek discussing the crucial Battle of Waterloo. Davros' plan is to give the French Empire total control over the world and to transform humanity into an ally of the Daleks. He intends to use Bonaparte's military genius to program the Daleks' battle computers. The Doctor used the mind-exchange device to swap bodies and force Davros to run from his own Daleks. He intends to use the device to wipe all Daleks' minds of Davros' influence and give them a new start.

Davros and the Supreme Dalek return to the command chamber. Davros orders the Doctor to be placed in a cell where he can suffer the pain of his infirm body. He and Flip are taken away.

Jared is recaptured by the French. Bonaparte orders him taken to the Daleks at the chateau. Jared is escorted by Captain Pascal. They encounter French soldiers whose minds have been

taken over by Daleks, wielding Dalek gunsticks. They are ordered to win the battle for Bonaparte. They march to war, chanting, "Exterminate!"

Bonaparte and Davros watch the battle. Bonaparte is proud of his achievements, but Davros reminds him that, without Dalek aid, he would have been defeated.

Jared and Pascal enter the chateau and release Flip and the Doctor. They go to the hatchery, where they find Dalek mutants with human minds floating in tanks. The mutants beg the Doctor for help. The Doctor tells Jared to collect Dalek weapons from the armoury and asks him to help the Prussians break through the French blockade. He gives Jared and Pascal prismatic forcefields to make them invisible.

They head into the battlefield. Pascal is mortally wounded, and Jared promises him that he will stop Bonaparte.

The Doctor assembles the upper half of a Dalek to use as a disguise. He and Flip return to the command centre. The Doctor tells Davros and the Supreme Dalek that he caught Flip outside her cell. Davros orders the Supreme Dalek to find the Doctor. Left alone, Davros soon finds himself the prisoner of Flip and the disguised Doctor. Flip paralyses Davros with a beam from a Dalek gun. She activates the mind-exchange device, and the minds of Davros and the Doctor return to their real bodies.

Jared offers the Duke of Wellington 20 Dalek guns and suggests that he use them to free the Prussian army.

The Supreme Dalek returns. It is not fooled by the Doctor. Davros demands that their minds be exchanged once more, but when the device is activated, it does not work. Davros tells the Supreme Dalek he is still in his original body, but he is not believed. He and Flip are taken away. The Doctor orders that Bonaparte be brought to him and the Daleks' minds be returned to their bodies.

The Doctor asks Bonaparte why he agreed to work with Davros. The French emperor explains that Davros took him through time to see his own future, where he met himself, living in exile. His older self described to him all the mistakes he made at Waterloo. The Doctor shoves Bonaparte into a compartment. Bonaparte overhears the Supreme Dalek's plan to replace his mind with a Dalek's. Bonaparte realises he has been tricked by Davros. "I have been betrayed," he says. "I demand revenge!"

Jared returns to the Duke of Wellington with the news that the Prussians have been freed and are on their way.

Bonaparte understands his choice: either he wins at Waterloo and becomes a Dalek puppet, or loses and becomes an exile. He chooses to deliberately lose.

The Doctor and Flip head for the Dalek hatchery. The Doctor tries to return the humans' minds to their real bodies, but Davros overloads the system and kills them all. A furious Doctor sends the Dalek mothership back into the vortex.

Davros awakens. He still has his memories. He laughs. "The mind wipe failed!" he exclaims. But the Supreme Dalek and all the others have no idea what they are. "Why am I in pain?" the Supreme Dalek asks. "Don't worry, my children," Davros says. "I will tell you everything you need to know. Listen carefully..."

The Doctor and Flip are reunited with Jared in the woods. The Doctor programs the Dalek ship to send them both home, but Flip jumps out just before it departs. She asks the Doctor to take her with him on his travels.

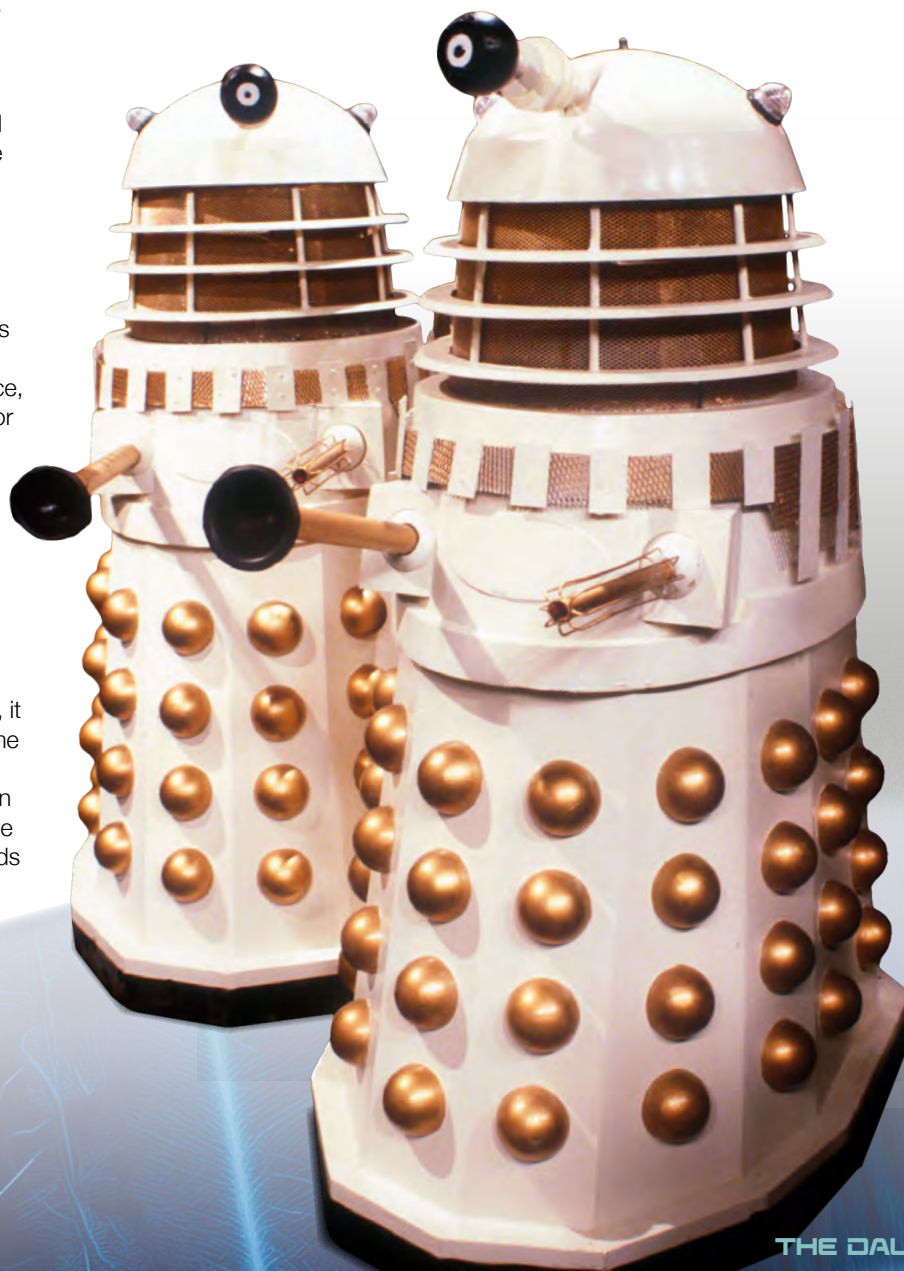



THE CURSE OF FATAL DEATH

This elaborate *Doctor Who* comedy sketch was written by future showrunner Steven Moffat for the BBC's Comic Relief night in 1999.

The Ninth Doctor (Rowan Atkinson) and his companion Emma (Julia Sawalha) are planning to marry, but cross paths with a hapless version of the Master (Jonathan Pryce) in a castle. To outwit the Doctor, the Master travels back in time and bribes the castle's architect to build the Spikes of Doom. However, the Doctor has travelled even further back in time and bribed the architect

to turn it into the Sofa of Reasonable Comfort. The Master enlists the Daleks' help by offering them the Zectronic Energy Beam, which the Doctor knows will allow them to conquer the universe in a matter of minutes. The Doctor is shot by the Daleks but regenerates into his tenth incarnation (Richard E. Grant), who describes himself as "lick-the-mirror handsome". However, an electric shock from the Zectronic Beam controller turns him into the Eleventh Doctor (Jim Broadbent), who is extremely shy around girls. He quickly regenerates into the Twelfth Doctor (Hugh Grant), which pleases Emma no end, but a discharge

of Zectronic energy mortally wounds him. The Master and the Daleks are overcome with admiration for their fallen enemy and vow to carry on his good works in his memory. But the Doctor suddenly regenerates again, this time into a woman (Joanna Lumley), much to Emma's disappointment but the Master's delight.

The Curse of Fatal Death is Steven Moffat's first broadcast *Doctor Who* script. He would, of course, go on to write several scripts for the revived series from 2005 and would take over as showrunner in 2010. Although very much played for comedic effect, *The Curse of Fatal Death* does feature elements that would also appear in Moffat's later, more serious, *Doctor Who* scripts.

Produced on a small budget, *The Curse of Fatal Death* re-purposed existing footage from the original TV series. The opening title sequence and theme tune were adapted from the versions used between 1974 and 1980, but with Tom Baker's face omitted from the time tunnel graphics. Similarly, the opening shot of the TARDIS in transit through space and time was taken from the opening moments of the 1996 TV Movie, which starred Paul McGann as the Doctor. As well as the familiar theme tune,



Rowan Atkinson and Julia Sawalha.



Joanna Lumley.



Jim Broadbent.



Hugh Grant.

musical director Mark Ayres re-purposed cues from previous *Doctor Who* episodes, including *Meglos*, *Logopolis*, *The Greatest Show in the Galaxy*, and *The Sea Devils*.

For similar cost-saving reasons, the TARDIS console and three Daleks were sourced from fan Ashley Nealfuller. These replica props had been constructed for a video project called *Devious*.

In addition to the *Devious* Daleks, three further Daleks were supplied by BBC Visual Effects: the Supreme Dalek from *Remembrance of the Daleks* now painted black and grey, plus two

Imperial-style Daleks constructed for the Children's Royal Variety Performance in May 1994, one of which had been repainted black and gold. Another Dalek was loaned by Dave Saunders of the toy manufacturer Dapol. Along with the black-and-gold Dalek, the others were various shades of silver and grey.

Nealfuller operated one of the Daleks and was joined by his colleagues Steve Cranford and David Clarke, as well as Chris Kirk who operated the black Dalek. Inside some of the other Daleks were Dave Chapman, Antonia Moss, and Mike Mungarvan (who had been a Dalek operator in *Destiny of the Daleks*).

As well as operating one of the props, Dave Chapman also provided some Dalek voices, alongside veteran Roy Skelton, who had performed the Dalek voices in many of their previous TV appearances since 1967's *The Evil of the Daleks*.

The Doctor's regeneration into a woman at the climax of the story was a first for *Doctor Who* on screen. However, the suggestion that the Doctor could be female had a long been a source of speculation among *Doctor Who* fans, and Joanna Lumley had often topped lists of suitable candidates for the role, should the opportunity ever arise.



In the studio with *The Curse of Fatal Death*.

BASE SECTION

INTERNAL SUPPORT STRUCTURE

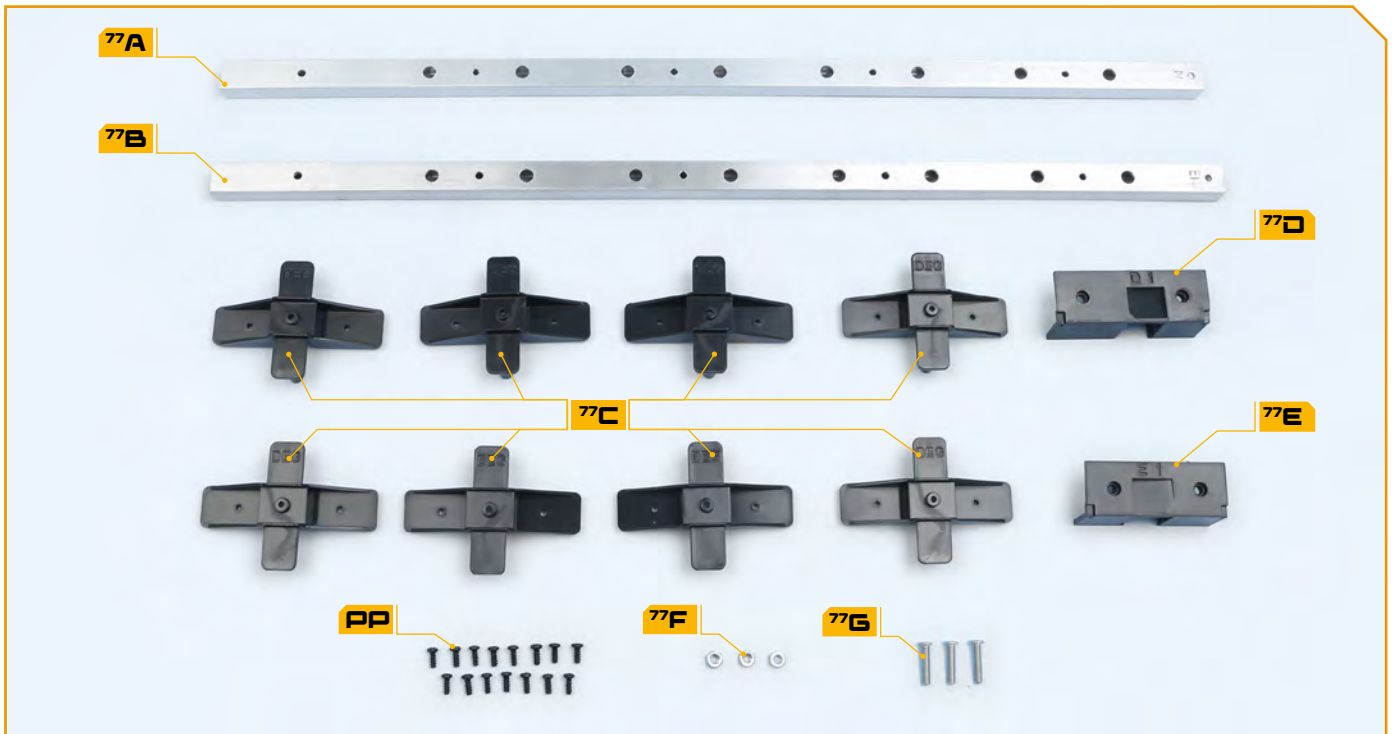

COMPONENTS OF ISSUE 77

77A SIDE SUPPORT (labelled D1)

77B SIDE SUPPORT (labelled E1)

77C EIGHT SKIRT FIXING PARTS (labelled DEG)

77D SIDE SUPPORT TOP JOINT (labelled D1)

77E SIDE SUPPORT TOP JOINT (labelled E1)

77F NUTS (x 3, 1 spare)

77G BOLTS (x 3, 1 spare)

PP FIFTEEN 2.6 X 6MM PB SCREWS (1 spare)

#76-01

Take the side support **77A** (marked D1) and four of the skirt fixing parts **77C**. Position them as shown, so that the raised screw holes on the skirt fixing parts fit into the large holes in part **77A**. Note that the label D1 on part **77A** is at the top. Fix each fixing part in place from the back of the side support **77A** with a **PP** screw.

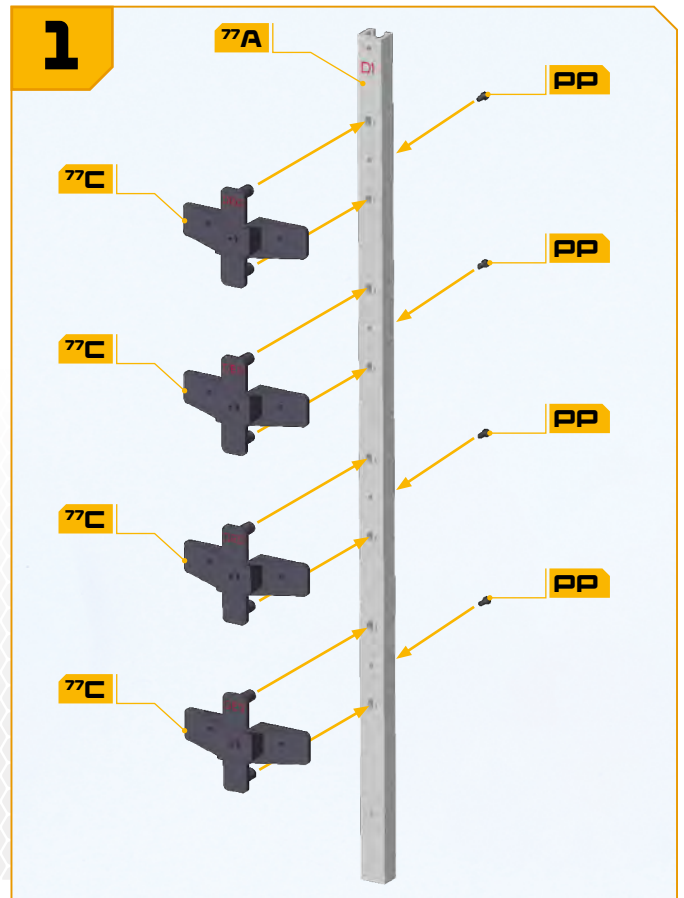

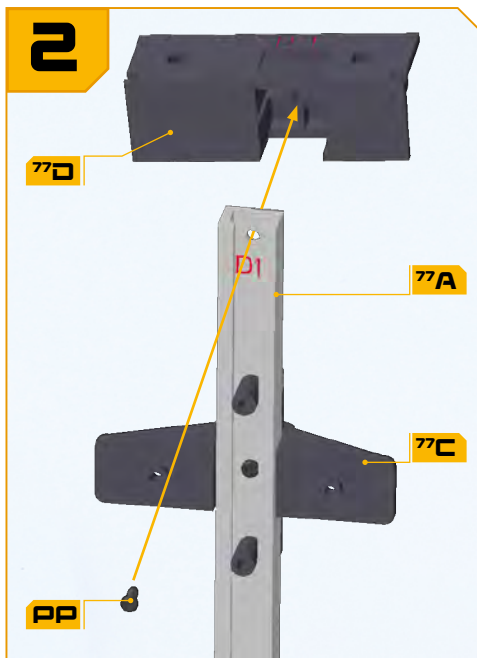

#77-02

Take the side support top joint (labelled D1) **77D** and fit the top of part **77A** into the recess so that screw holes are aligned. Note the orientation of the parts with the channel in part **77A** and the raised screw sockets in parts **77C** are facing forwards. Fix in place with a **PP** screw.

#77-03

Fit the base of the side support **77A** into the channel in the next skirt support, half way down the right-hand side. Fit the top joint **77D** into the corresponding shape marked D1 in the side of the chest support **72A**. Fix in place with two **PP** screws (inset).

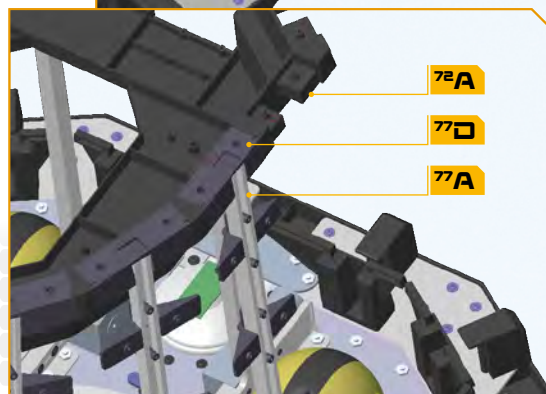
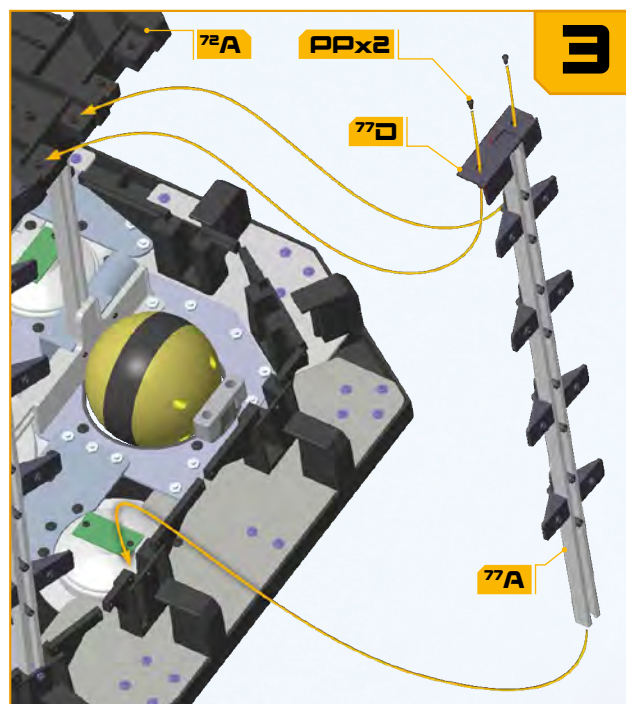

#77-04

Fit a bolt **77G** through the screw holes in the skirt holder and part **77A** (yellow arrow).

Fit a nut **77F** on the end of the bolt to hold it in place (red arrow). Use the spanner **38F** to help tighten the nut if necessary.

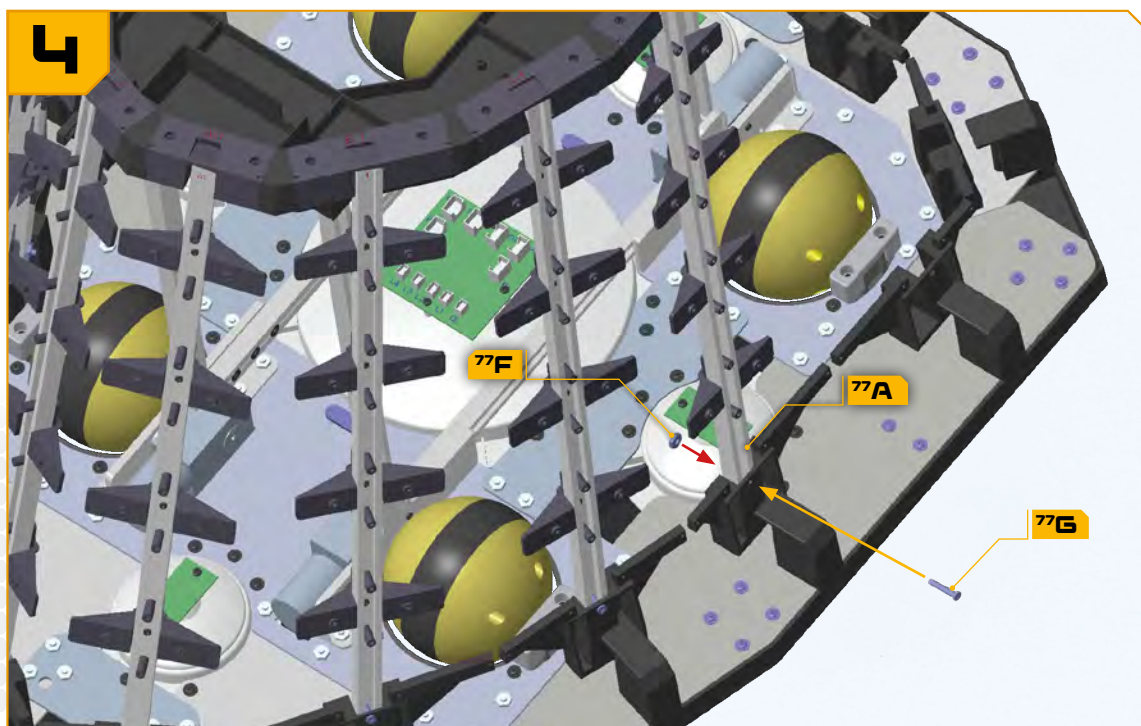

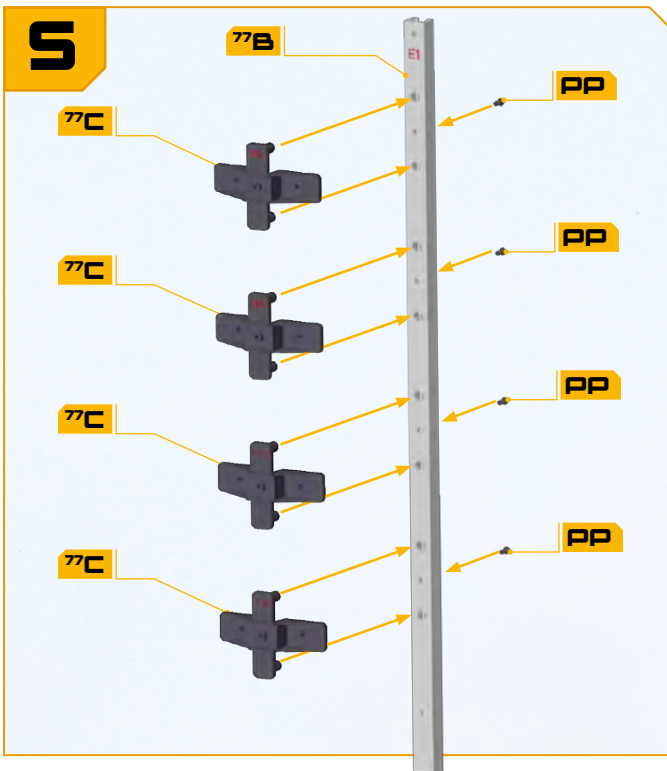

#77-05
 Take the side support **77B** (marked E1) and the remaining four skirt fixing parts **77C**. Position them as shown, so that the raised screw holes on the skirt fixing parts fit into the large holes in part **77B**. Fix each fixing part in place from the back of the side support **77B** with a **PP** screw.

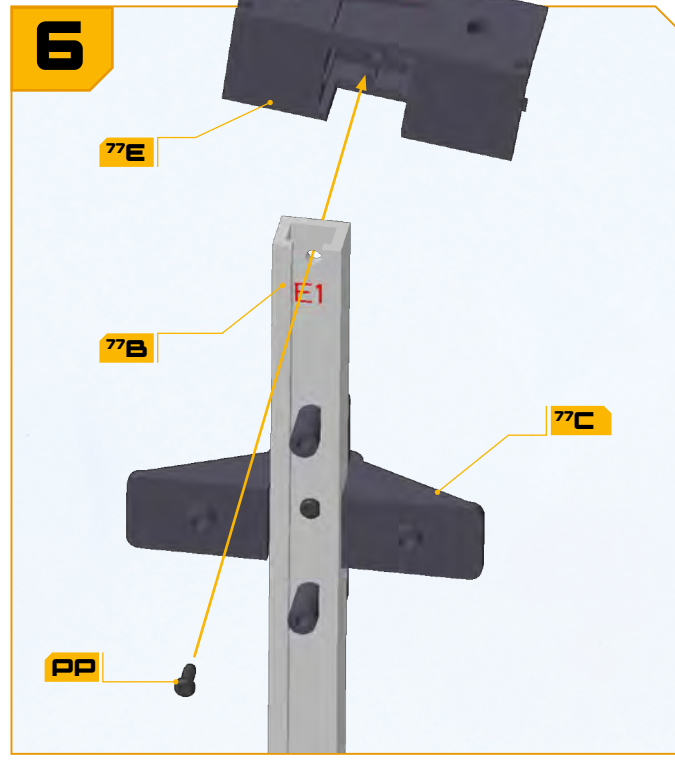

#77-06
 Take the side support top joint (labelled E1) **77E** and fit the top of part **77B** into the recess so that screw holes are aligned. Note the orientation of the parts with the channel in part **77B** and the raised screw sockets in parts **77C** are facing forwards. Fix in place with a **PP** screw.

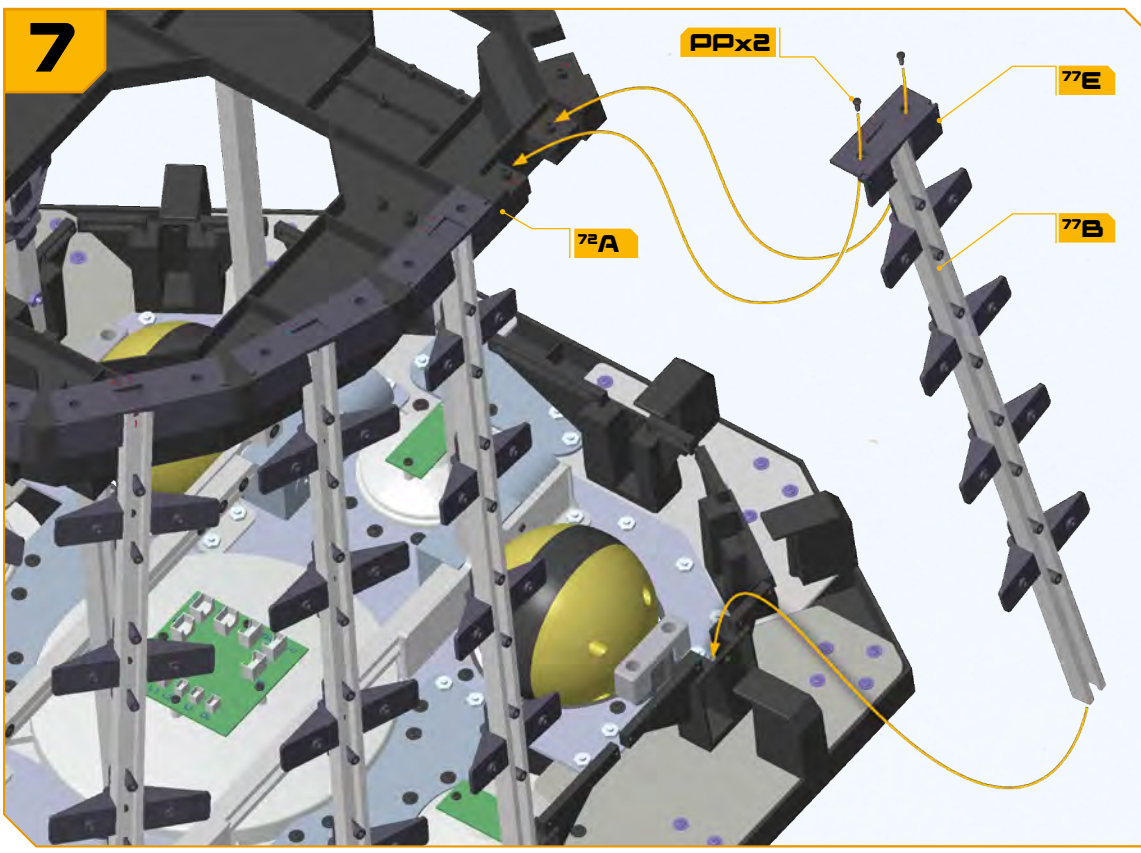

#77-07
 Fit the base of the side support **77B** into the channel on the inner side of the next skirt support beside the rear left wheel wheel. Fit the top joint **77E** into the corresponding shape in the side of the chest support **72A**, which is marked **E1**. Fix in place with two **PP** screws.

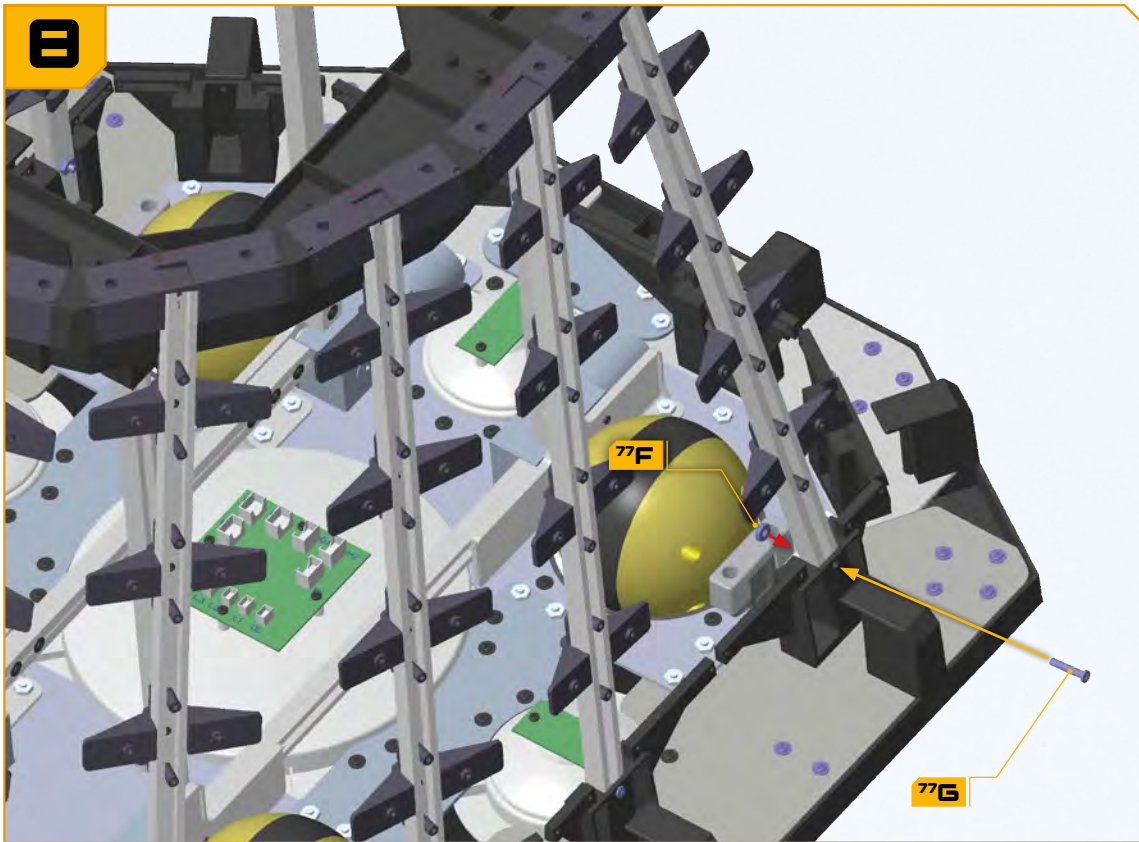
8**#77-08**

Fit a bolt **77G** through the screw holes in the skirt support and part **77B** (yellow arrow). Fit a nut **77F** on the end of the bolt to hold it in place (red arrow). Use the spanner **38F** to help tighten the nut if necessary.

COMPLETED WORK**#077 COMPLETED WORK**

Skirt supports have been fitted on the left-hand side of your model.

THE DALEK



COMING IN
ISSUE 78

BUILD PART 78

Issue 78 continues the base structure build with eight skirt fixings, two more side supports, side supports joints and the required nuts and bolts.

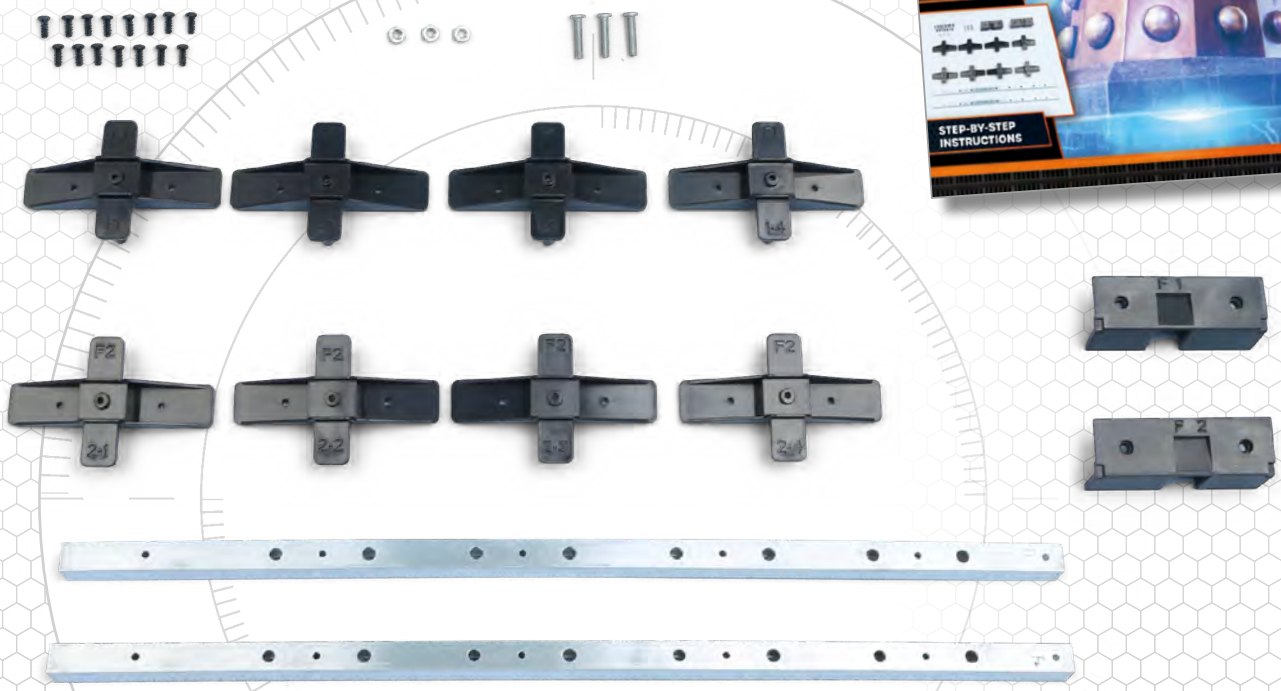

THE TIME VORTEX



The War Doctor continues his lifelong crusade to end the Last Great Time War and finally defeat the Daleks once and for all.

ADVENTURES IN TIME AND SPACE



Pursued by the Daleks, the Doctor and his friends must avoid capture and are forced to make a landing on *The Devil's Planet*.

Every week at your newsagent! Visit hachettepartworks.com/Dalek